

NOTICE OF PROPRIETARY RIGHTS

THIS DOCUMENT CONTAINS CONFIDENTIAL TECHNICAL DATA INCLUDING TRADE SECRETS, PROPRIETARY TO GRAYSTONE INDUSTRIES SYSTEMS. DISCLOSURE OF THIS DATA IS EXPRESSLY CONDITIONED UPON YOUR ASSENT THAT ITS USE IS LIMITED TO USE WITHIN YOUR COMPANY ONLY. ANY OTHER USE IS STRICTLY PROHIBITED WITHOUT PRIOR WRITTEN CONSENT OF GRAYSTONE INDUSTRIES.

NOTES: (UNLESS OTHERWISE SPECIFIED)

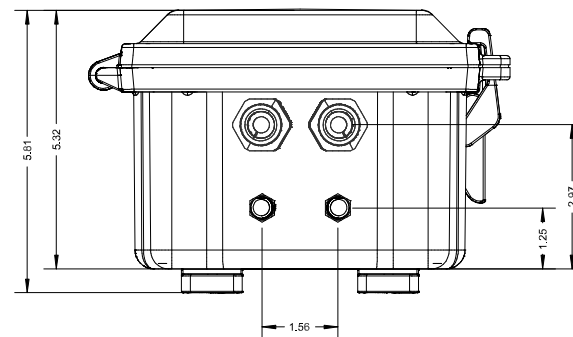
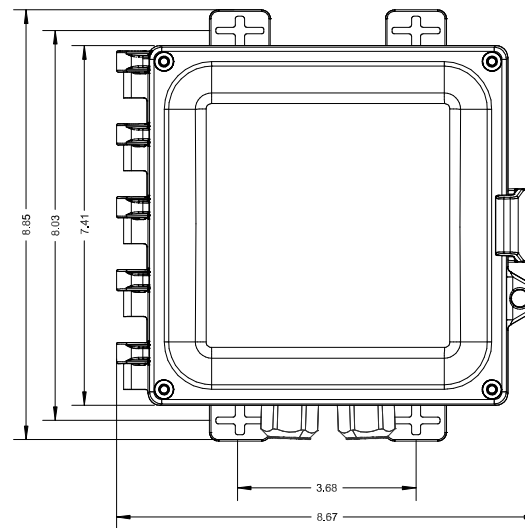
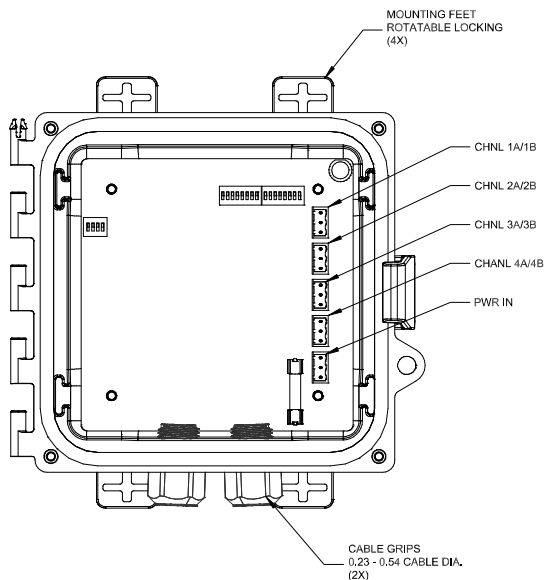

DESCRIPTION:
PHALANX 4 CHANNEL VOLTAGE INPUT TRANSCEIVERS FOR INDUSTRIAL, SCIENTIFIC & AUTOMATION APPLICATIONS.

SPECIFICATIONS:

FREQUENCY:	2.4GHZ, FHSS
RX SENSITIVITY:	-100dBm
CONFIGURATIONS:	NETWORK ADDRESSES: 256, USER SELECTABLE VIA DIP SWITCH NETWORK FREQUENCY CHANNELS: 16, USER SLECTABLE VIA DIP SWITCH NETWORK ENDPOINTS SUPPORTED: UP TO 16, USER SELECTABLE VIA DIP SWITCH
MAIN ANTENNA INPUT:	TNC FEMALE
WIFI ANTENNA INPUT:	TNC FEMALE
REGULATORY:	TRANSCEIVER: FCC PART 95 (NO LICENSE REQUIRED) EMI: FCC PART 15 & EN55022 COMPLIANT
TX/RX RANGE:	OPTION-1YZ, US/CA MODEL, 300FT INDOOR/URBAN, 1 MILE LINE OF SIGHT OPTION-1YZ, EU MODEL, 100FT INDOOR/URBAN, 300FT LINE OF SIGHT
ENCLOSURE:	MATERIAL: POLYCARBONATE MOUNTING: POLE OR PANEL WEIGHT: 3lbs
ENVIRONMENTAL:	OPERATING TEMPERATURE: -30deg-C TO +65deg-C HUMIDITY: 100% RH, CONDENSING IP RATING: IP67
CHANNEL INTERFACES:	INPUT SENSOR TYPE: VOLTAGE INPUT, 5-24VDC NUMBER OF INPUT CHANNELS: 4 EACH, 4kV ISOLATION, TRANSIENT PROTECTED TERMINAL TYPE: OST P/N EDSTL955/3 LED INDICATOR MODES: TX/RX, POWER ON, LINK LOST, ASSOCIATION & CHANNEL HOP
OPTIONS:	OPTION-XY0: 12-48VDC OPERATING VOLTAGE, EMI FILTER, FUSED, TRANSIENT PROTECTED OPTION-XY1: 120-240VAC OPERATING VOLTAGE, EMI FILTER, FUSED, TRANSIENT PROTECTED OPTION-1YZ: 10mW TX POWER OUTPUT OPTION-2YZ: 100mW TX POWER OUTPUT OPTION-X0Z: WITHOUT WIFI ACCESSIBILITY OPTION-X1Z: WITH WIFI ACCESSIBILITY

MATERIAL:	POLYCARBONATE
FINISH:	USED ON ASSY.

ITEM	P/N	DESCRIPTION	QTY	NOTES
<p>UNLESS OTHERWISE SPECIFIED</p> <p>ALL DIMENSIONS ARE IN INCHES MACHINED SURFACES FINISH 32 RMS MAX. REMOVE ALL BURRS 0.015 MAX. BREAK MACHINE CORNERS 0.005 MAX. FILLET R. TOLERANCES ON DECIMALS XX ± 0.01 XXX ± 0.005 ANGLES 4.1° FRACTIONS ± 1/32</p>				
<p>GrayStone Automation Automation & Wireless Solutions 203 Gold Creek Dr. - Dayton Nevada - 89403 TELE: 775-315-3524</p>		<p>TITLE TRANSCEIVER, PHANLANX 2.4GHZ VOLTAGE INPUT</p>		
<p>SIZE C</p>		<p>DWG NO 10-910056-XYZ</p>		<p>REV A</p>
<p>DO NOT SCALE DRAWING</p>		<p>CAGE CODE</p>	<p>SCALE 1:2</p>	<p>SHEET 1 OF 1</p>